

STF88 Four Output Ports Amplifier

Features:

- ✦ Four RF output ports, use GaAs power doubling module, max. output level up to 127dB μ v.
- ✦ Equipped with Automatic Level Control (ALC). Use super-low distortion circuit design for ALC control circuit.
- ✦ ALC circuit is placed in common forward path. It is able that output level compensation for cable loss at 4 output ports to be controlled by the ALC circuit.
- ✦ Output level of 4 output ports are controlled by a plug-in attenuator pad, no need to re-regulate ALC circuit.
- ✦ Reverse signal level of 4 ports to be controlled independently by plug-in attenuator pad.
- ✦ Every GaAs amplifier module equipped with an independent transient voltage suppression diode, ensure GaAs amplifier module operating reliably.
- ✦ Input and output of reverse amplifier module are equipped with an independent arrester protector.
- ✦ Use 100W high efficiency switching power supply, 50% remaining power.

Specifications:

Frequency range	Forward	(54-862)MHz		
	Reverse	(5-47)MHz		
Gain(dB)	Forward	Min.	Typ.	Max.
	Reverse	34	38	40
Flatness (dB)	Forward	20	21	22
	Reverse		± 0.5	± 0.75
Rating input level (dB μ V)	Forward		± 0.5	
	Reverse		70 ± 4	
Rating output level (dB μ V)	Forward		108	
	Reverse			
Max. Output level (dB μ V)	Forward		127 ^①	
	Reverse		120	
ALC accuracy	$V_{in}=70\text{dB } \mu\text{V} \pm 3\text{dB}$	$\Delta V_o = \pm 0.5\text{dB}$		
	$V_{in}=70\text{dB } \mu\text{V} \pm 4\text{dB}$	$\Delta V_o = \pm 0.8\text{dB}$		
CTB(dB)	Forward		-66 ^②	-62
	Reverse		-	-
Cross modulation(dB)	Forward		-65 ^③	-60
	Reverse		-	-
CSO(dB)	Forward		-65 ^④	-62
	Reverse		-	-
Second order distortion	Forward		-65 ^⑤	-60
	Reverse		-	-
Noise Figure(dB)	Forward			
	100MHz		4.5	
	550MHz		5.0	
	750MHz		6.0	
Return loss (dB)	F&R		16	14
Thunderstroke immunity	5KV(8/20 μ s)			
Power Consumption	DC+24V/2.6A, AC60V, 50Hz/1.1A			

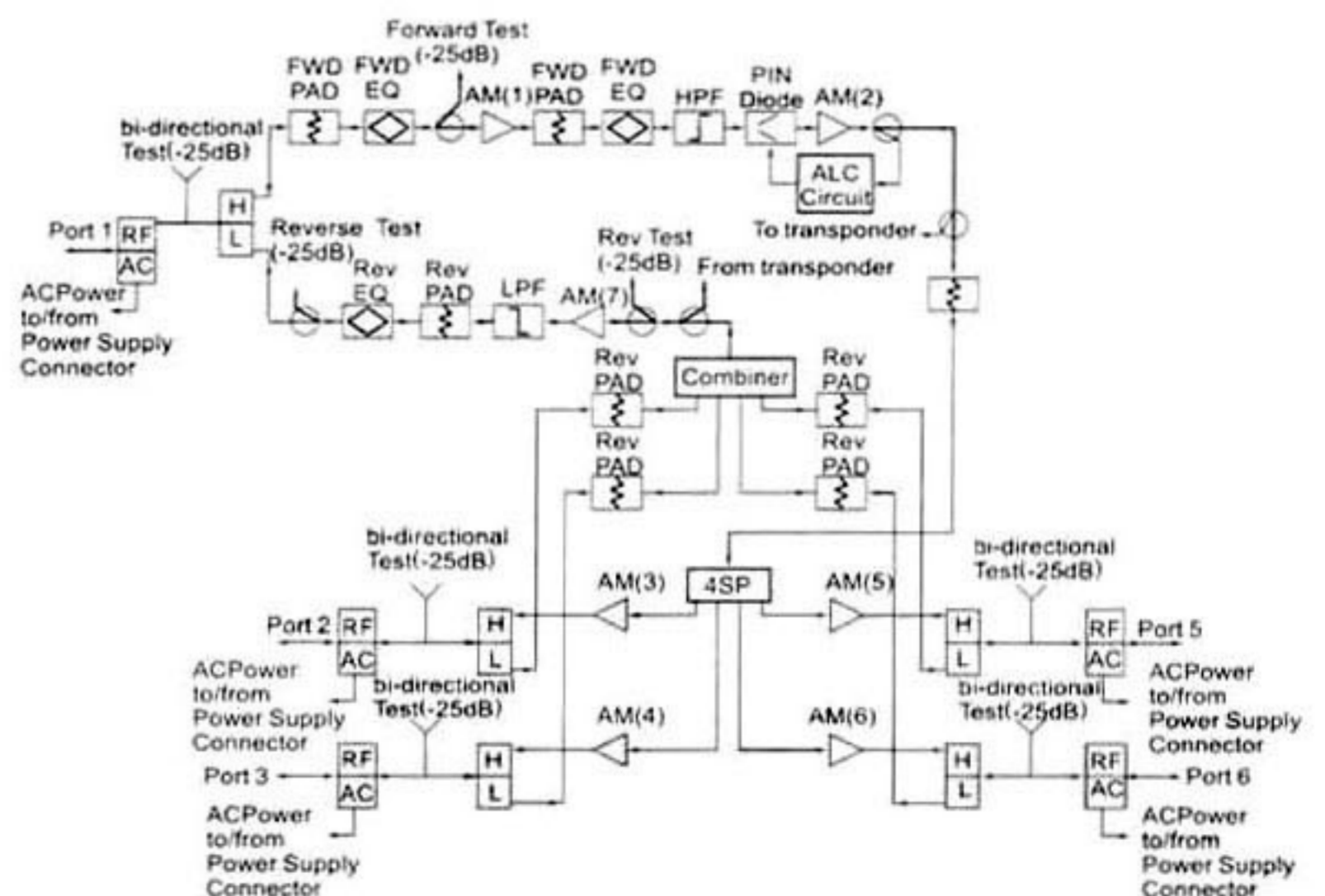

STF88 Functional Block Diagram

Notes:

- ① Max. output level (per output port) is measured at -60dB cross-modulation ratio (DIN45004B)
- ② 135 channel flat; $V_o=108(\text{dB } \mu\text{V})$; measured at $f_m=859.25\text{ MHz}$.
- ③ 135 channel flat; $V_o=108(\text{dB } \mu\text{V})$; measured at $f_m=55.25\text{ MHz}$.
- ④ 135 channel flat; $V_o=108(\text{dB } \mu\text{V})$; measured at $f_m=860.5\text{ MHz}$.
- ⑤ $f_p=55.25\text{ MHz}$; $V_p=108(\text{dB } \mu\text{v})$; $f_q=805.25\text{ MHz}$; $V_q=108(\text{dB } \mu\text{v})$; measured at $f_p+f_q=860.25\text{ MHz}$.